

Reconstruction of ice sheet movement from the orientation of linear glacial landforms and glaciotectionic deformations near Kronowo (western Mazury, Poland)

Wojciech MORAWSKI



Morawski W. (2003) — Reconstruction of ice sheet movement from the orientation of linear glacial landforms and glaciotectionic deformations near Kronowo (western Mazury, Poland). *Geol. Quart.*, 47 (4): 339–356. Warszawa.

Ice sheet movement in northeastern Poland is reconstructed from analysis of the spatial orientation of glacial landforms and glaciotectionic deformations. The orientations of both positive and negative glacial landforms (morpholineaments) of the Vistulian Glaciation were analysed. These landforms form 4 sets and follow an original crevasse system (joint net) within the ice sheet, probably resulting from horizontal stress exerted as the ice advanced from the north. Esker deposits have been glaciotectionically deformed to form a compressional fan fold, due to limited movement of the ice sheet prior to deglaciation. This movement caused the ice crevasses to be tightened and cut by strike-slip faults. Movement here was from the NNW, as determined from the orientation of deformations. Thus, the ice-flow direction changed at least by 10° during the last phase of the Vistulian Glaciation. If the ice rotated the northeastern portion of the esker, this change may have amounted to 30°.

Wojciech Morawski, Polish Geological Institute, Rakowiecka 4, 00-975 Warszawa, Poland; e-mail: wmor@pgi.waw.pl (received: April 15, 2003; accepted: July 3, 2003).

Key words: Mazury, Vistulian Glaciation, ice sheet movement direction, morpholineaments, glaciotectionic.

INTRODUCTION

The study area is located in western Mazury, northeastern Poland (Fig. 1). Fieldwork was conducted over 1998–2000 as part of the making of the *Detailed Geological Map of Poland*, scale 1:50 000, and covered an area of about 300 km² (Morawski, 2003a). The study area is located 50 km to the north of the maximum ice sheet limit of the Vistulian Glaciation (Morawski, 1999). This is a glacial plateau (Fig. 1) where different glacial landforms are extremely well preserved, particularly negative and positive linear glacial landforms, i.e. surface morpholineaments (Piątkowska, unpub.) (Fig. 2). They form a pattern which suggests a relation to crevasses (joint net) within the ice body. This paper examines the relationship between this net and ice-flow direction.

Near Kronowo there is an esker (Fig. 2), and its sand and gravel deposits are exploited in a substantial. Exposures reveal strong compressional glaciotectionic deformations which were analysed in detail in 1998–2002. These investigations identified the deforming stress direction. The author compared the

ice-flow direction determined theoretically from the orientation of the original crevasse system in the ice sheet with the ice-flow direction that caused the glaciotectionic deformations. This procedure enabled reconstruction of ice sheet movement during the Main Stadial of the Vistulian Glaciation.

PREVIOUS METHODS OF RECONSTRUCTING ICE SHEET MOVEMENT

Previous methods were based mainly on till fabric measurements, orientation of linear glacial landforms, i.e. morpholineaments and glaciotectionic deformations.

CLAST FABRIC

Reconstruction of local ice sheet movement from the orientation of elongated clasts is based on measurements taken in exposures (e.g. Glen *et al.*, 1957; Karczewski, 1963; Stankowski, 1975; and others). This method is difficult to apply in the area studied due to the insufficient number of tills exposed on the

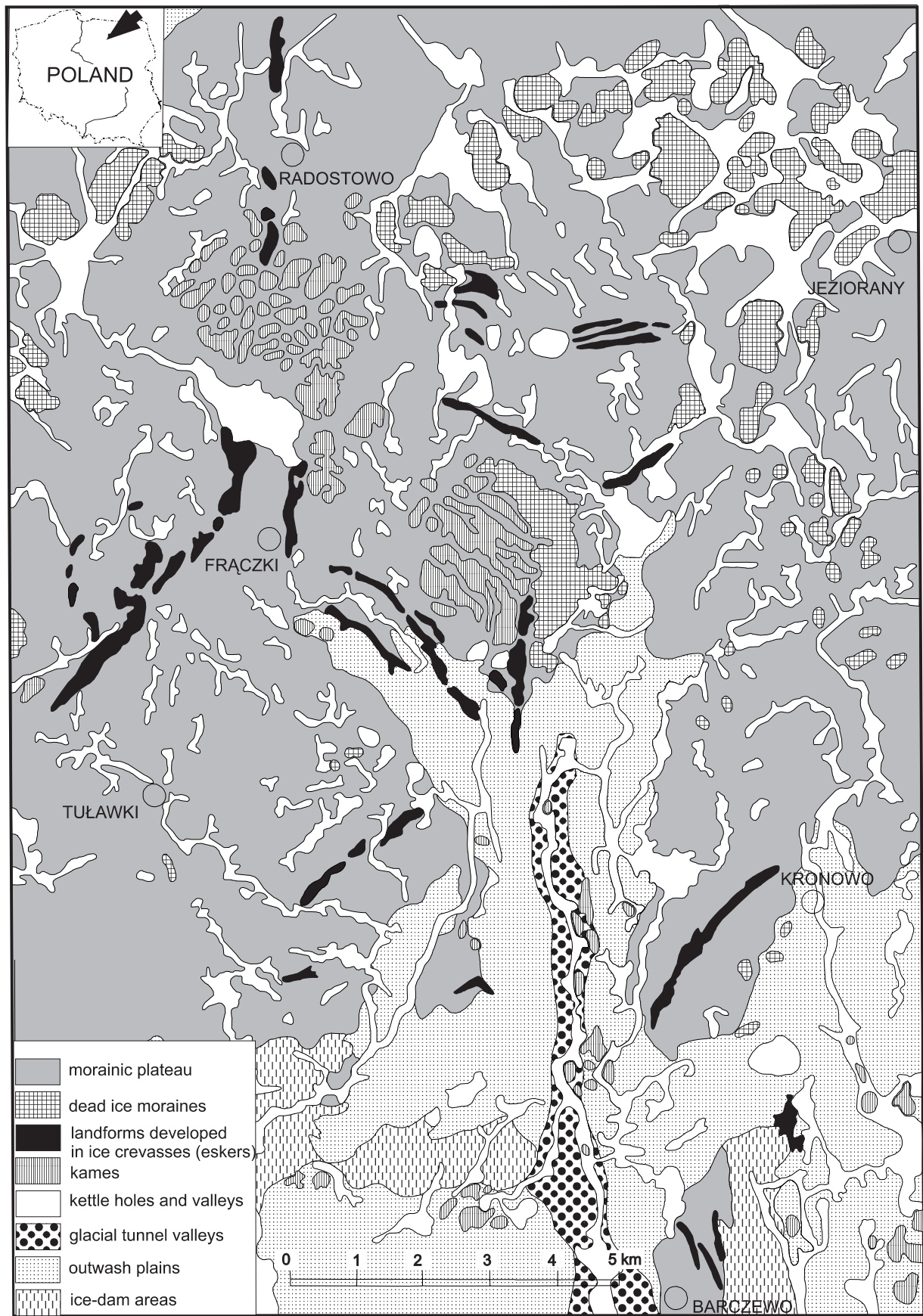

Fig. 1. Geomorphological sketch of the Kronowo region

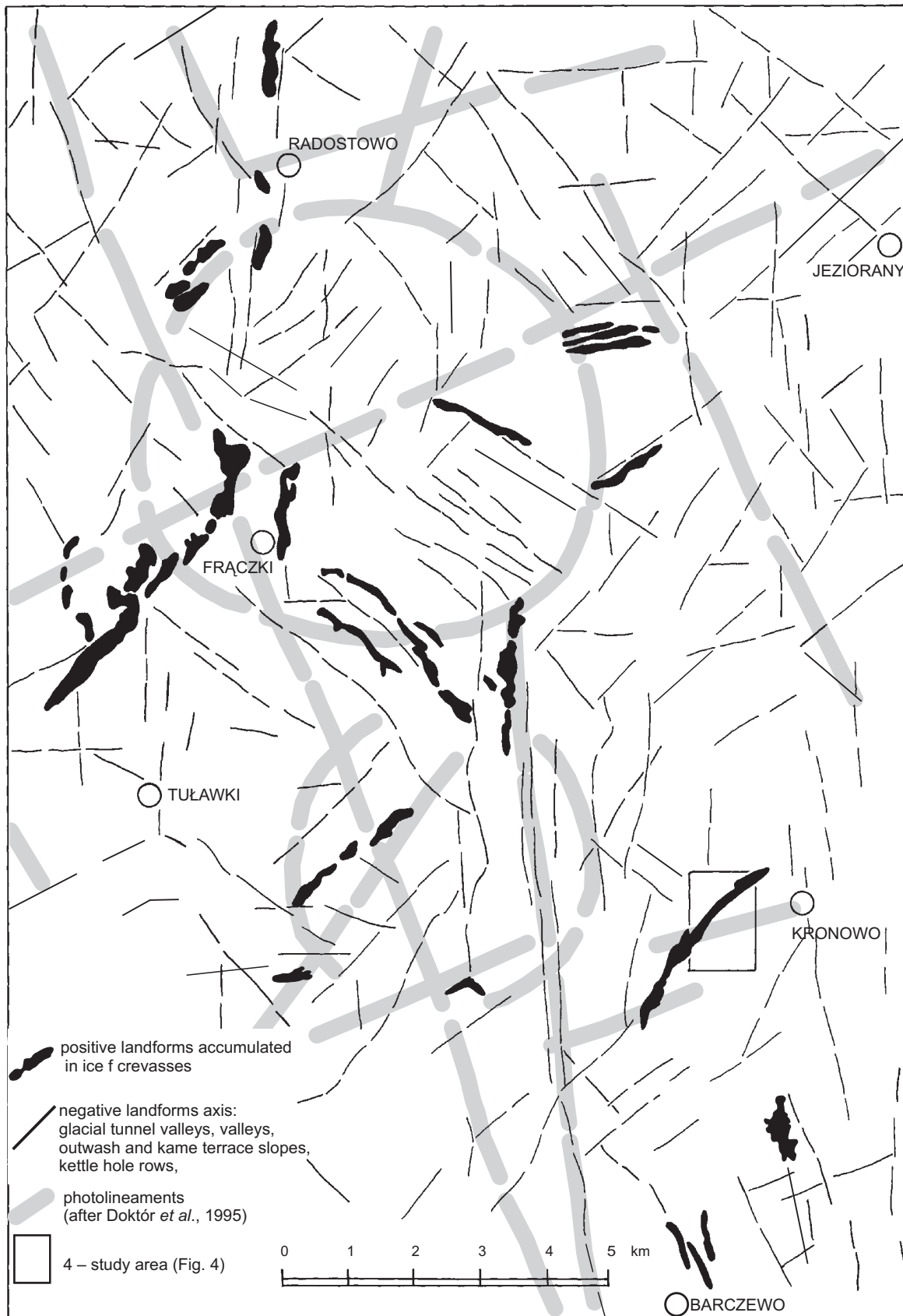

Fig. 2. Morpholineaments in the Kronowo region

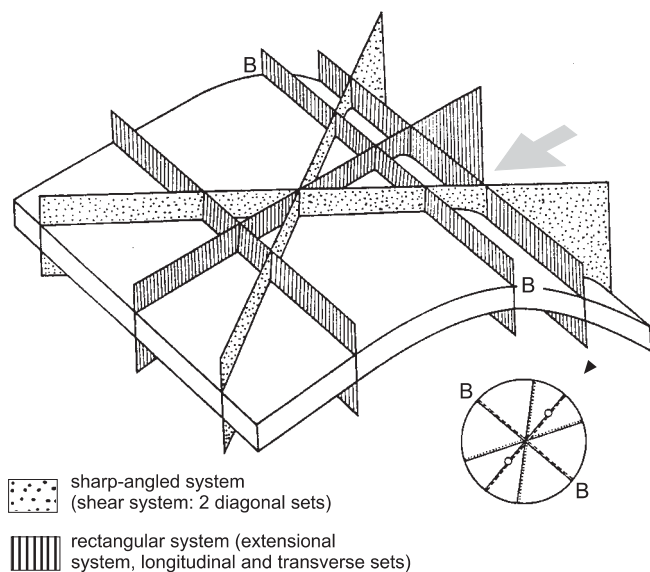

Fig. 3. Classical pattern of joints (crevasses) (after Dadlez and Jaroszewski, 1994, simplified and supplemented)

Projection into upper hemisphere, circles denote bedding poles; arrows denote stress vector

morainic plateau. As a rule, exposures in northeastern Poland occur in sand and gravel pits of depositional glacial landforms. Tills, that commonly occur in this type of exposures, are usually represented by flow tills and therefore have no regional stratigraphic significance. Clast fabric in flow tills reflects mud flow direction (Morawski, 1984), and locally it corresponds to the inclination of the front of the ice sheet. The pebbles, also, may show random orientations. Flow tills can also occur in i.e. watermorainic complexes in different positions relative to the ice sheet mass: proglacially, supraglacially, subglacially or englacially (Morawski, 1985, 1989).

Only lodgement till and meltout till show diagnostic features for identification of ice sheet movement. Orientation of clasts in these tills can be a result of ice sheet movement due to ice-flow (e.g. Shaw, 1977; Rusczyńska-Szenajch, 1998), or a result of dynamic deposition caused by friction against the basement (*cf.* Boulton, 1975). Tills of these facies, however, in most cases do not occur at the surface in NE Poland i.e. they are unavailable for direct observations in natural exposures. Pebble orientation, inherited after ice sheet movement, can subsequently be changed both by till deformation during deposition (Hart, 1995; Boulton, 1996) and by later glaciotectionic deformation.

These circumstances mean that reconstruction of local ice sheet movement from orientation of clasts is of little use to regional investigations in northeastern Poland.

ORIENTATION OF MORPHOLINEAMENTS

Orientation of linear glacial landforms (morpholineaments) assumes that they are generally oriented according to the direction of ice sheet advance. Drumlins seem to be the most highly diagnostic (e.g. Aario, 1977; Piotrowski, 1987; Wysota, 1994; and others), although in many cases they are winding landforms and do not always reflect the real direction of ice-flow. Among other landforms, glacial tunnel valleys are commonly

considered to be oriented along the ice-flow direction, assuming that they run perpendicularly to the ice sheet front (e.g. Majdanowski, 1947, 1950; Ber, 2000; and others). Similar interpretations may be applied to subglacial eskers, in particular those observed in Scandinavia (e.g. Bergdahl, 1953).

GLACIOTECTIONIC DEFORMATIONS

Studies of glaciotectionic deformations have been performed for over a century and have included both examinations in exposures and interpretations of borehole profiles. They include theoretical investigations supported by modelling and observations in recently glaciated areas, and have been comprehensively discussed (e.g. van der Meer, 1987; Croot, 1988; Aber *et al.*, 1989), also by Polish authors (Bartkowski, 1968; Rotnicki, 1974, 1976, 1988; Brodzikowski, 1982, 1987; Rusczyńska-Szenajch, 1983; Pasierbski, 1984; Marks, 1992; Dadlez and Jaroszewski, 1994; and others). These authors suggest that glaciotectionic structures form as a result of a dynamic (movement) or static (loading) effect of a glacier, exerted on its basement or immediate forefield. Starting with the suggestion of Gripp (1938), there has been a dominant opinion that glaciotectionic deformations occur in front of the ice sheet. Analyses in exposures should determine whether any deformation structures present are of compressional origin — e.g. reverse faults, slices or thrusts. In such a case the ice sheet front undoubtedly deformed both those sediments in the forefield which were an obstacle to the advancing ice, and the ice sheet's own deposits e.g. glaciomarginal fans at its front. Measurement of the orientation of deformation structures enables reconstruction of the deforming stress, i.e. the direction of ice sheet movement (e.g. Ber, 1987; Aber and Rusczyńska-Szenajch, 1997; Rusczyńska-Szenajch, 1999; Morawski, in print *a*). Compressional deformations, formed as a result of horizontal stress, should accurately reflect local ice sheet advance, i.e. the direction of its local movement.

Such investigations are most commonly performed for push-moraines, e.g. in glaciomarginal fans when the ice sheet advance resumed after a temporary stagnation (e.g. Kasprzak, 1985; Morawski, in print *a*). Such investigations focus on marginal zones where, however, local movement of ice sheet front did not always reflect the general direction of advancing ice sheet.

Of particularly significance for the reconstruction of the general direction of ice sheet movement are glaciotectionic deformations formed far from the marginal zone. Such deformations are observed in the Kronowo esker, and will be discussed hereafter.

STUDY METHODS

To reconstruct the direction of ice sheet movement on the basis of the original crevasse system, i.e. the original stress field within the ice sheet, the Kronowo region was selected (Fig. 1). Detailed geological studies and maps a scale of 1:25 000 were made (Morawski, 2003) and 1:10 000. Studies of the orientation of glaciotectionic deformations were performed in the sand and gravel pit.

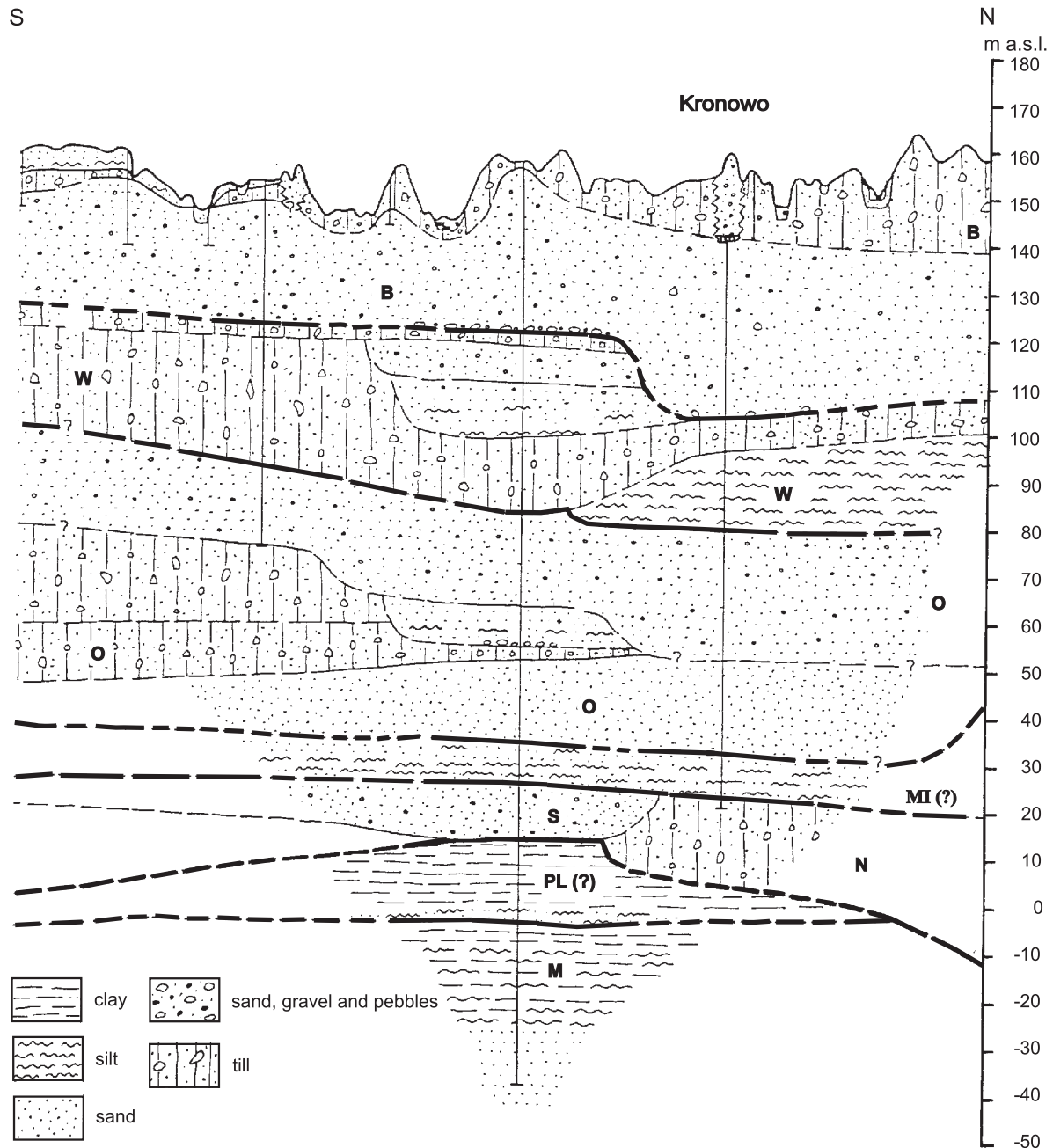

Fig. 4. Geological cross-section (after Morawski, 2003, simplified)

M — Miocene, PL — Pliocene, N — Narevian Glaciation (Menapian), S — Sanian Glaciation (Elsterian), MI — Mazovian Interglacial (Holstenian), O — Odranian Glaciation (Saalian 1), W — Wartanian Glaciation (Saalian 2), B — Vistulian Glaciation (Weichselian); for location see Figure 7

GEOMORPHOLOGICAL ANALYSIS

Results of the geomorphological analysis of the study area are shown in a geomorphological sketch map (Fig. 1). All linear landforms (morpholineaments), both positive and negative, were analysed in detail. Positive landforms are represented by eskers and the ridge-like landforms deposited in ice crevasses. Negative linear landforms are represented by glacial tunnel valleys, outwash plains (valleys) and kame terraces, melt-water valleys and kettle holes. These morpholineaments are shown in a separate sketch map (Fig. 2). Azimuth and length measurements were taken for individual landforms — a 1 km-long section rep-

resents a single measurement. The results are shown in rose diagrams constructed for all of the morpholineaments as a whole, and separately for negative and positive landforms using the *StereoNet* software. A total length of 38 km of positive and 228 km of negative landforms is shown in the diagrams. All morpholineaments identified in the study area were measured.

Discussion. My investigations (Morawski, 2000, in print) suggest that the orientation of morpholineaments observed in northeastern Poland, including in particular glacial tunnel valleys and ridges formed in ice sheet crevasses, is commonly arranged in 4 sets: a N–S set (corresponding to the assumed general direction of ice sheet advance), a longitudinal set, and 2 sets oblique to

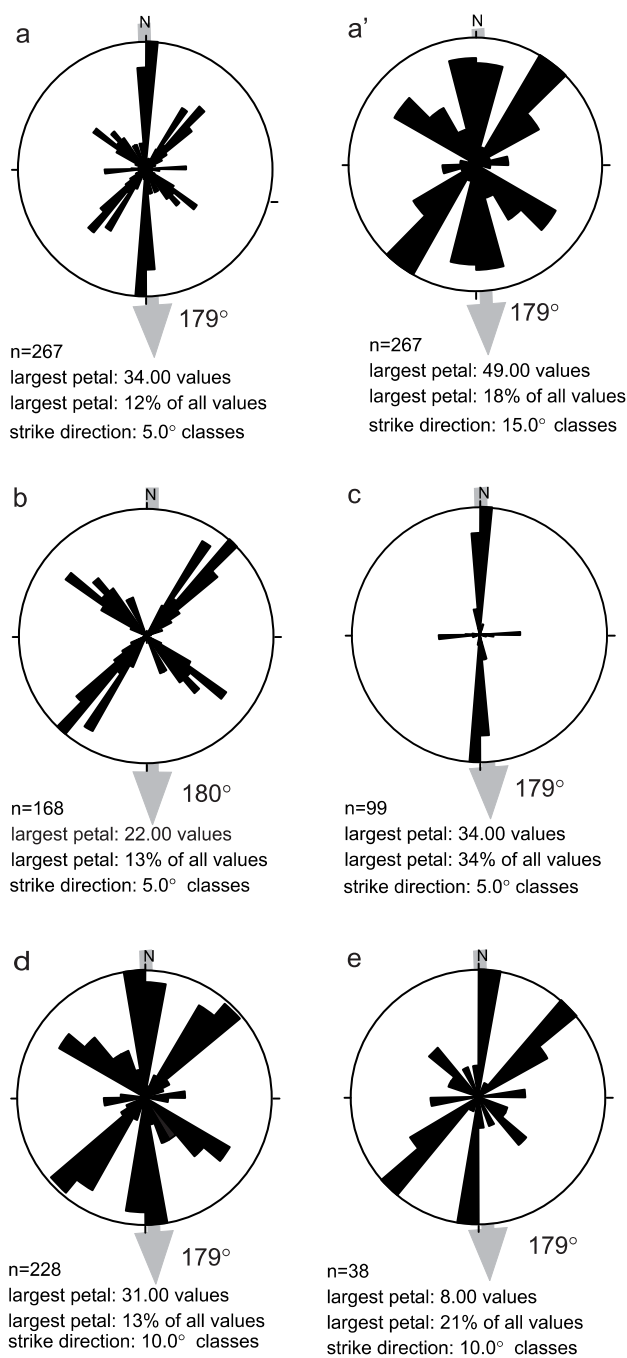

Fig. 5. Orientation of morpholineaments (see Fig. 2)

a — composite diagram of positive and negative landforms, a' — the same diagram, simplified (15° classes), b — shear (sharp-angled) system composed of 2 oblique (diagonal) sets, c — extensional (rectangular) system composed of 2 sets (longitudinal set and transverse set), d — composite diagram of negative landforms, e — composite diagram of positive landforms; arrows denote the resultant stress vector (ice sheet movement direction), the azimuth value close to arrows

the N–S one. The nature of these morpholineaments and their spatial distribution suggest that they were formed along a net of ice crevasses (joints). This is the way in which the classical joint net is developed as a result of horizontal stress. The net is composed of a rectangular system (extensional system composed of a longitudinal set and a transverse set), and a system at an angle to these (a shear system, composed of 2 diagonal sets) (Fig. 3). This net is typical of folds, though according to Jaroszewski

(Dadlez and Jaroszewski, 1994), there is no reason to relate the net to any folding process in terms of its origin, because it also occurs in unfolded areas.

It has been assumed for the purpose of these investigations that the ice crevasses developed within the ice sheet due to horizontal stress caused by the advancing ice. This advance was hindered by various obstacles located in front of the ice sheet, and hampered by friction against the basement. This process proceeded probably in advancing dynamic ice which caused horizontal stress. Therefore, directions of ice sheet movement can be derived from the orientation of the original crevasse system as the resultant of the 2 oblique sets (shear system) which are commonly best developed. For example, from the resultant of 2 major sets of glacial tunnel valleys or linear depositional landforms formed in ice fissures. Only some linear landforms can directly indicate the direction of ice sheet movement: the N–S set of extensional system.

SEDIMENTOLOGICAL ANALYSIS

The study area shows a range of landforms which accumulated in the fissures of the ice sheet. Some of these comprise sand and gravel deposits, worked in large pits. Of particular interest are exposures located in the Kronowo gravel pit where detailed sedimentological analyses of sand and gravel deposits filling a crevasse have been performed (Gruszka and Morawski, 2003; Fard, Gruszka and Morawski, in prep.). Azimuth measurements were taken to determine the dip of cross-bedding in sand and gravel deposits. The measurements were taken in various sites of the pit, i.e. in different zones of the crevasse filling, and subsequently plotted on the diagram illustrating palaeoflow directions.

ANALYSIS OF GLACIOTECTONIC STRUCTURES

The Kronowo exposures reveal a broad glaciotectionic fan fold, successively investigated and documented along over a 500 m-long section of the pit, as the quarrying continued though 1999–2002. Investigations focused on detailed structural analysis of the deformations. Stratal dips, measured in both fold limbs, were projected onto rose diagrams using the *StereoNet* software. The data obtained were used to determine the fold compression vector which represents the direction of deforming ice sheet movement.

STRATIGRAPHIC POSITION

The sub-Quaternary surface in this area is composed of Miocene sands, silts or clays, and only locally of variegated clays of the Pliocene or Upper Miocene (Poznań Formation — Piwocki, in print a) (Fig. 4).

The study area comprises a large territory called the Pleistocene Warmia sedimentary province by Morawski (2003b). The province is characterised by an incomplete Pleistocene succession strongly influenced by meltwater and glacial erosion, and glaciofluvial sedimentation. Marker tills are discontinuous, occurring as thin lenses at different depths. The sub-Quaternary

topography is highly diverse with glaciotectionically disturbed Tertiary deposits locally even squeezed up to the surface. Such a reduced Pleistocene succession probably reflects a labile substrate (Morawski, 2003*b*; in print *a*). It may be supposed that Tertiary, and also perhaps Quaternary tectonic movements (Motyl-Rakowska and Schoeneich, 1970), caused or triggered the development of major features of the sub-Quaternary topography. This may concern in particular extensive elevations and depressions of the sub-Quaternary substrate. The approximate N–S trend of these landforms corresponds according to Marks (1988) to the trend of sub-Cainozoic structures.

The regional succession of Pleistocene deposits is known from many boreholes, including cored and sampled scientific boreholes. They have provided little stratigraphical data since the Pleistocene sections are incomplete and lithological and petrographical analyses are available only for 3 tills: an upper till (Vistulian); a middle till (Wartanian: Saale 3); and a lower till (Nidanian: Elster 1 — glacial A) (Kenig, 2000, unpubl.). No interglacial organogenic deposits older than Eemian have been encountered over the study area or in neighbouring areas. Therefore, the Pleistocene stratigraphy of this area is based on lithological correlation of geological strata along several geological cross-sections (Morawski, 2003*a*), tied to regional stratigraphical interpretations (e.g. Mańkowska and Słowański, 1968, 1980; Morawski, in print *b*).

A simplified stratigraphy is given in a geological section (Fig. 4) a cross the Kronowo pit area from N to S.

GLACIAL LINEAR LANDFORMS — MORPHOLINEAMENTS

Amongst various morphological and genetic types of glacial landforms, only few occur chaotically, showing no clear arrangement. In positive (depositional) landforms, this is typical mostly of dead ice moraines, primarily kames. Amongst negative landforms, kettle holes associated with dead ice blocks are commonly chaotically distributed, although they are locally arranged in linear rows. Most glacial landforms are oriented. They are represented in particular by those marginal landforms which follow the limit of the temporarily stagnant ice sheet front, e.g. arc-like frontal moraines. On the plateau landscape, most of both positive and negative glacial landforms are arranged in linear rows, i.e. they occur in the form of morpholineaments.

The study area is a part of an extensive morainic plateau of the Vistulian Glaciation (Fig. 1). This area is morphologically diverse, altitudes above sea level ranging from about 100 to 200 m, and the relative height of some of landforms is up to 70 m. Most of the area represents a hummocky glacial plateau composed of till and various depositional landforms. In the north-east of the area (Fig. 1), the glacial plateau lies at 110 to 130 m a.s.l., and is characterised by the occurrence of numerous small lakes and dead ice moraines. In the east, the plateau area is located at altitudes of 140–160 m a.s.l. Topographic relief is of the order of several to a dozen metres, the surface drainage system is poorly developed, kettle holes are frequent and shallow, and single depositional landforms are low. The western part of the glacial plateau shows a different character and is located at

150–175 m a.s.l. Very numerous, small kettle holes (with lakes and swamps) and a number of other small landforms represented mainly by drumlins occur in this area. The highest topographic peaks reach 160–180 m a.s.l. and are observed in the central northern part where two large elongated kame fields occur at nearly 200 m a.s.l. (Fig. 1).

NEGATIVE FORMS

Kettle hole rows. These are numerous, small and shallow in the glacial plateau. There are also extensive depressions with a depth of over 20 m, some of which are occupied by lakes or peat bogs. These are probably kettle holes developed after dead ice remains. Some of them are distinctly elongated or are arranged in linear rows that may indicate that they follow original zones of crevasses in the ice. The plateau's drainage system is poorly developed, though there is a series of dry valleys which often join to form kettle holes. Linear segments of these valleys may also reflect original systems of ice crevasses.

Outwash plains (valleys). Small areas in the centre and south of the study area are covered by outwash and ice-dam plains as well as by kame terraces (Fig. 1). The outwash plain is represented by a N–S-trending belt in the central part of the study area. This area is inclined southwards from approximately 150 in the north to 115 m a.s.l. to the south. This is a flat area covered with infrequent, very shallow and commonly N–S elongated hollows. Similarly situated outwash plains are observed in the neighbouring areas. They represent a source area; the northern extremities of vast outwash linear plains were formed during the retreat of the ice sheet. Outwash plains widen southwards to form several terraces (Morawski and Kenig, 1999). Outwash linear plains are genetically associated in this area with large landforms deposited at northern ends of crevasses in the ice. They represent the succeeding phase of deglaciation during which meltwaters flowed away after kame terraces had formed. Boundaries of these areas are visibly linear and their orientation has probably been inherited after a N–S system of original ice crevasses. During deglaciation, meltwaters either followed ice-free areas between ice crevasses, widening them, or flowed along extensive crevasse zones.

Glacial tunnel valleys. A N–S trending glacial tunnel valley occurs in the central-southern part of the study area (Fig. 1). It is perpendicular to the outwash plain and kame terraces, and is incised down to 140 m a.s.l. (in the north) and to 115 m a.s.l. (in the south). This tunnel valley is 30 deep in the south, its depth decreasing northwards. The valley floor has both thresholds and local hollows partly filled with several metres-thick organic deposits. There is also a series of landforms interpreted as kames. Tunnel valley slopes are steep, and in some places there are moderately extensive outwash fans located at slope bases. Small valleys transecting the glacial plateau, and kettle hole rows are probably both also of glacial tunnel origin. These are all negative landforms showing linear trends and forming a N–S set probably inherited after the original crevasse (joints) set in the ice sheet and approximately consistent with its movement direction.

The spatial orientation of these negative linear landforms (Fig. 2) is shown in a diagram (Fig. 5*d*). All of these are arranged

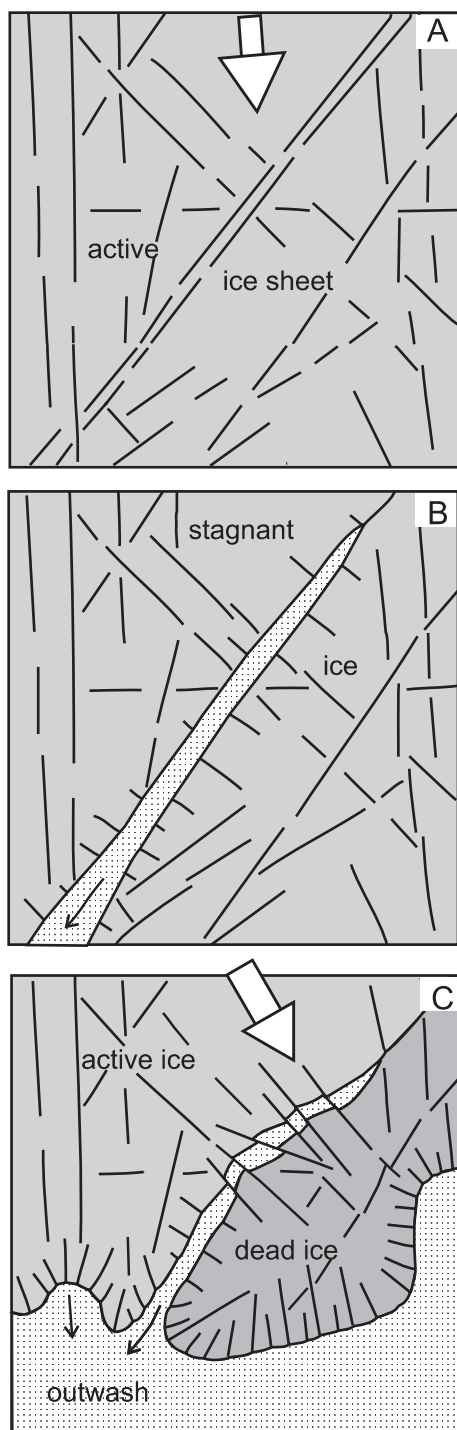

Fig. 6. Schematic representation of the Kronowo crevasse development

A — original joint net (arrow indicates the direction of ice sheet movement), B — open crevasse creation, C — glaciotectonic faulting and rotation (arrow indicates the direction of ice sheet movement)

in a net composed of 4 sets: a very well developed N–S set, 2 oblique sets, and a very poorly developed longitudinal set.

POSITIVE LANDFORMS

Positive depositional linear landforms, including eskers, developed in ice crevasses. They may be observed throughout

the glacial plateau (Fig. 1). They are represented by variably sized landforms, ranging from ridges which are several tens of metres wide and a few metres high (e.g. in the center of the study area) to 300 metres wide and several tens of metres high (e.g. in the west). The length of these landforms varies from about 100 m up to several kilometres e.g. the Kronowo esker (Fig. 2). Some of them are not continuous ridges but linear rows of hills. All of the positive linear landforms are spatially arranged to form a net composed of 4 sets (Fig. 5e) similar to the sets of negative linear landforms discussed above.

MORPHOLINEAMENTS AND PHOTOLINEAMENTS

The system of glacial linear landforms was compared with the photolineament pattern of satellite images (Doktór *et al.*, 1995). A comparison of photolineaments with linear landforms (Fig. 2) indicates that photolineaments do not reflect surface morpholineaments. The only exception is the N–S glacial tunnel valley and the accompanying edge of the outwash plain and kame terraces, west of Kronowo (Figs. 1 and 2, central-south part). This is a large landform and, therefore, shows as a photolineament on a satellite image. If the assumption that photolineaments reflect basement structures is correct (Graniczny, 1989), then the present analysis shows that glacial linear landforms, and thus the original crevasse (joint) net in the ice sheet, has no clear relationship with basement structures on a local scale. Such relationships are, however, clearly observed on a regional scale in the case of large linear landforms, e.g. a several tens of kilometres-long linear zone of deposition that occurred between ice sheet tongues, east of the study area (Morawski, 2003b; in print a).

ORIENTATION OF MORPHOLINEAMENTS AND ICE SHEET MOVEMENT DIRECTION

The glacial morpholineaments described above are arranged in a net composed of 4 sets (Fig. 5a). This pattern probably follows the original joints (crevasse) system within the Vistulian Glaciation ice sheet. The net consisted of a system composed of 2 sets oblique to the general N–S direction of ice movement (Fig. 5b), i.e. a NW–SE set and a NE–SW set. The sets cross each other at an extremely high angle of 87°, untypical of shear systems. This is almost a right angle, as in the case of surfaces of greatest shear. Nevertheless, if we assume that this is a conjugate system created as a result of shear, then the shear angle for the ice sheet would be 43.5°, and the internal friction angle only 3°. The resultant azimuth of the stress vector is 179.5°.

The other sets are represented by an approximately N–S trending set, consistent with the general direction of ice sheet movement. The longitudinal (W–E) set is perpendicular to the direction of the ice sheet movement. These sets cross each other at right angles, suggesting that they compose an extensional (rectangular) system (Fig. 5c). The resultant azimuth of the stress vector for this system is 179.1°.

Therefore, the question arises as to whether these are 2 separate systems formed as a result of different mechanisms and at different times, or whether this is a single conjugate system. The analysis performed shows that individual morpho-

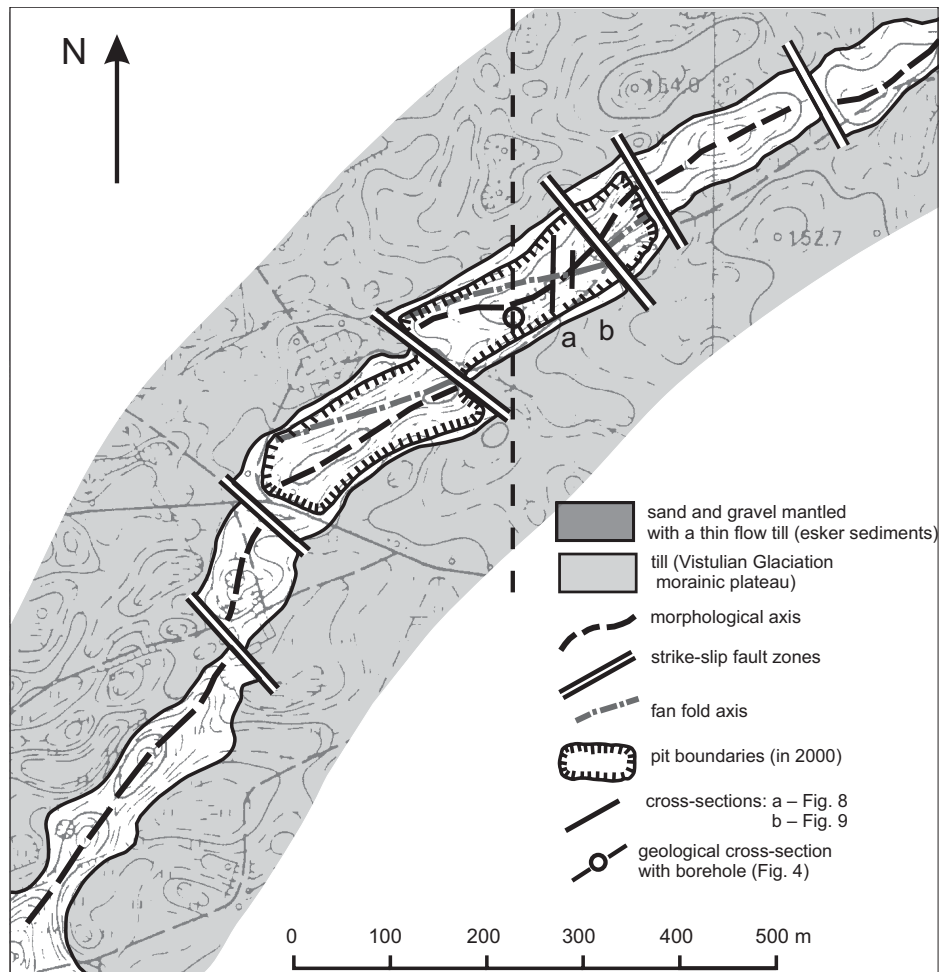

Fig. 7. Sketch of the Kronowo esker

For location see [Figure 2](#)

lineaments of both the shear and extensional system are not shifted relative to one another, indicating that they were probably formed simultaneously. The same values of resultant azimuths of the stress vector calculated separately for individual morpholineament systems also indicate that the entire pattern, composed of 4 sets, can be treated as a single conjugate system formed as a result of compressional stresses. Thus, the resultant azimuth of the stress vector for the entire crevasse system, or a net composed of 2 original crevasse systems, determined from the orientation of glacial positive and negative landforms deposited in ice crevasses, is 179.3° ([Fig. 5a](#)). Assuming a simplified situation that crevasses (joints) in the ice body formed due to stresses caused by ice sheet movement, i.e. as a result of horizontal stress, the ice sheet advance seems to have occurred almost exactly from the north. Thus, this was the general movement direction of the advancing ice sheet during the initial phase of the Main Stadal of the Vistulian Glaciation in this area ([Fig. 6A](#)).

A very similar northerly movement of the ice sheet — vector azimuth 183° — was inferred for the Nidzica region (about 50 km south of the study area) along a 50 km-long marginal zone of the ice sheet's maximum limit (Main Stadal of the Vistulian Glaciation). This value was obtained from a comparable analysis of the spatial orientation of glacial tunnel valleys

which are the dominant linear glacial landforms in that area (Morawski, in print a).

Analysis of individual sets of linear landforms (joints — crevasses in the ice body) indicates that the system of 2 oblique sets, treated together as complementary sets (shear system), is dominant. The N–S set only seems dominant because it is highly ordered, as shown by comparing the diagram constructed for 5° ([Fig. 5a](#)) with the diagram constructed for 15° ([Fig. 5a'](#)).

During successive phases of ice sheet advance, local movement of the ice body caused a widening of joint (fissure) zones followed by a formation of crevasses ([Fig. 6B](#)) both on sets oblique to the movement direction and, perhaps, on the parallel set. However, the longitudinal set, perpendicular to the stress direction (direction of ice sheet movement), was tightened and therefore used to a minimum extent as pathways for englacial water flow, and subsequently also used in the formation of both negative and positive depositional landforms. This is probably why the set is so poorly developed, considering both negative and positive glacial landforms ([Fig. 5d, e](#)).

The orientation of glacial linear landforms, discussed separately for positive (deposited in crevasses) and negative landforms ([Fig. 5d and e](#)), shows much similarity. Resultant azimuths of the stress vector for separately-considered glacial systems of positive and negative landforms formed in ice cre-

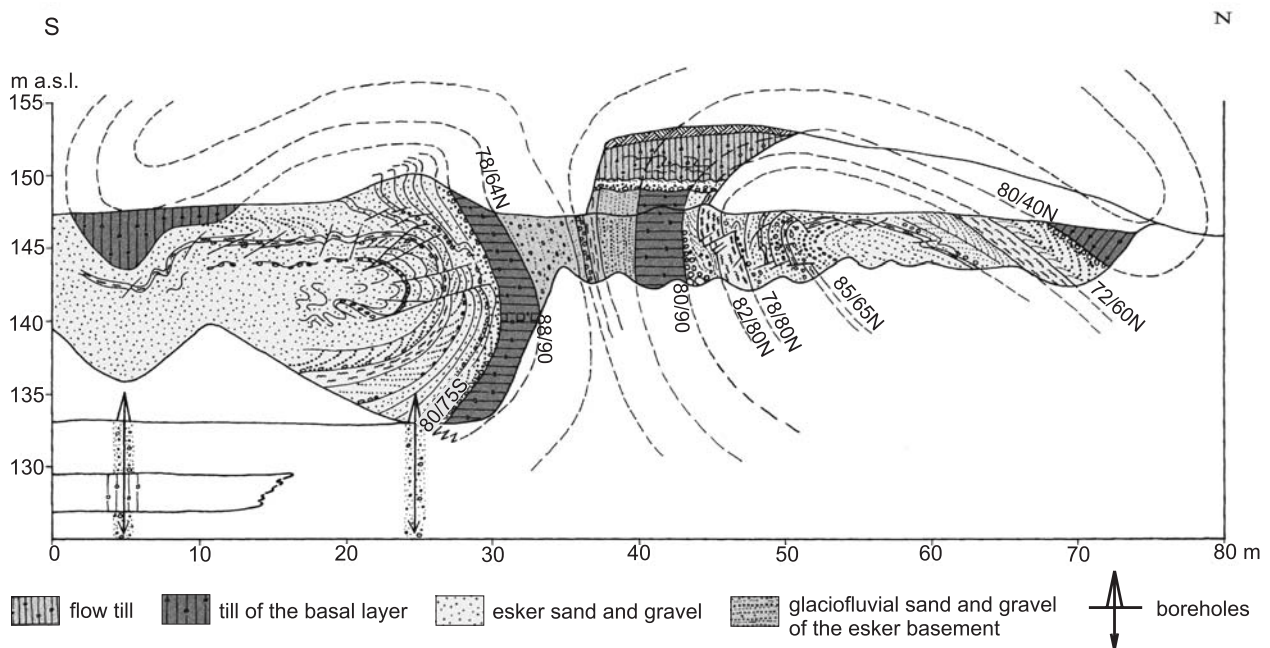

Fig. 8. Geological cross-section of the pit walls (see Fig. 7, cross-section a) with interpretation of glaciotectionic fold

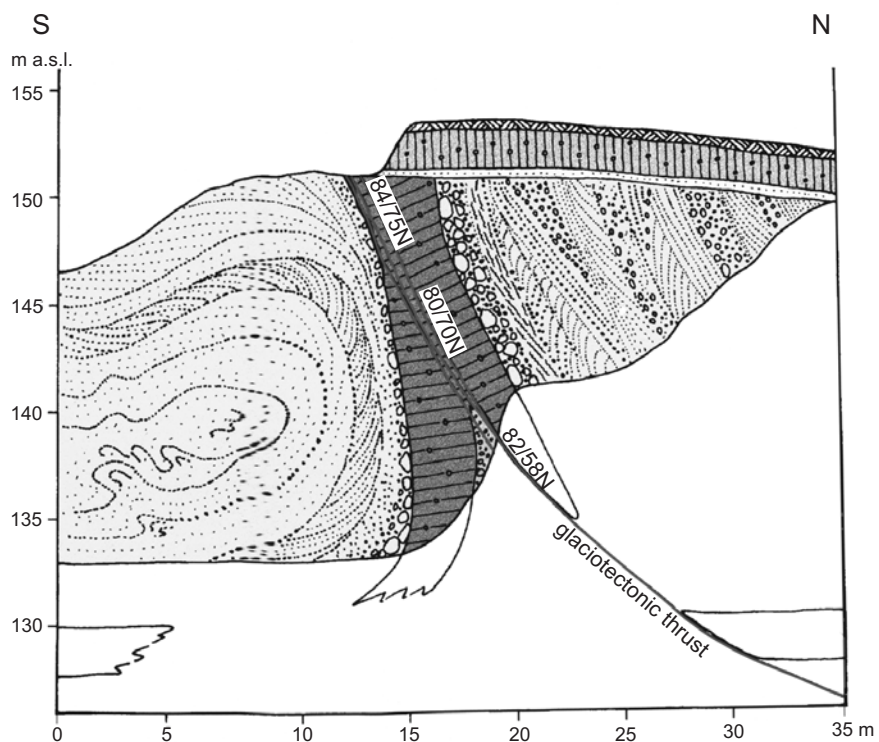

Fig. 9. Geological cross-section of the pit walls (see Fig. 7, cross-section b)

For explanations see Figure 8

vasses are almost identical and amount to 178.6° (Fig. 5d) and 179.3° (Fig. 5e), respectively. Moreover, 2 oblique sets are characterised by a dominance of the NE–SW set, in particular for landforms accumulated in crevasses (Fig. 5e). This diversity may result from e.g. local changes in different parameters within the ice body. It may also suggest non-simultaneous

opening of individual crevasse systems used by melt waters, maybe during changes in the general direction of ice sheet movement. Therefore, it is possible that the positive and negative landforms were formed non-simultaneously, and as a result of different processes. Landforms created in ice crevasses were perhaps formed prior to negative landforms, excluding proba-

bly glacial tunnel valleys. Therefore, gradual change in the direction of ice-movement could be reflected by various glacial linear landforms. This enigmatic problem requires further investigations over a large area, since it can be a local phenomenon unrelated to the origin of these landforms. The studies on the orientation of glacial tunnel valleys in the Nidzica region (Morawski, in print *a*) showed a considerable dominance of the NW–SE set.

KRONOWO ESKER

The linear landform located at Kronowo, 20 km NE of Olsztyn (Fig. 2), was earlier interpreted as a frontal moraine, basing on investigations in a small exposure (Mańkowska and Słowański, 1968, 1980; Zieliński, 1992). Intensive exploitation of sand and gravel deposits began in 1998 and resulted in the excavation of a pit over 500 m long (Fig. 7) and 20 m deep at the end of 2002. This large exposure enabled detailed and comprehensive analyses. Studies in the migrating exposures, as the quarrying continued, rendered possible detailed geological documentation both of deposits accumulated in the ice crevasse (Gruszka and Morawski, 2003; Gruszka, Mokhtari Fard and Morawski, in prep.) and glaciotectionic deformations.

The Kronowo esker is over 3 km long and approximately 200 m wide. It runs from the NE towards the SW, with a slight ENE deviation in its eastern part. This landform is represented by a row of elongated hills from several to a dozen of metres high. It runs across an hummocky glacial plateau covered with till, several to over 20 m thick (Fig. 4). The azimuth of the morphological axis of this landform varies from NE to SW, ranging between about 55 to 30°. In the Kronowo exposure the azimuth is approximately 50°. Towards NE, this landform disappears under a thickening morainic cover. Towards SW, it extends as far as the N–S outwash plain, and, further on, it forms a coarse-grained, gravelly outwash fan, passing south-westwards into a finer-grained ice-dam succession (Fig. 1). This situation shows that the Kronowo ice crevasse was a pathway for a substantial flow of meltwater during deglaciation (Fig. 6B).

FILLING OF THE CREVASSE

At culminations of individual hills, reaching 150–160 m a.s.l., along the linear ridge of the Kronowo esker, sand and gravel glaciofluvial deposits are exposed on the surface. Elsewhere on the ridge, they are covered by a flow till. The top of the esker, an erosional surface (about 150 m a.s.l.), is disconformably covered by a thin pavement layer and poorly sorted, massive deposits (Figs. 8 and 9) followed by a light brown sandy flow till containing clearly visible flow structures indicating transport in mud flows. The thickness of this till ranges up to about 8 m in the northeastern part of the exposure.

Thickness of the sand and gravel esker deposits varies from a dozen to over 20 metres. The deposits are represented largely by cross-bedded poorly sorted sands and gravels, and gravels.

65 measurements were taken to determine the dip of the dominant trough cross-bedding in glaciotectionically undeformed deposits at various sites of the exposure. The azimuth of

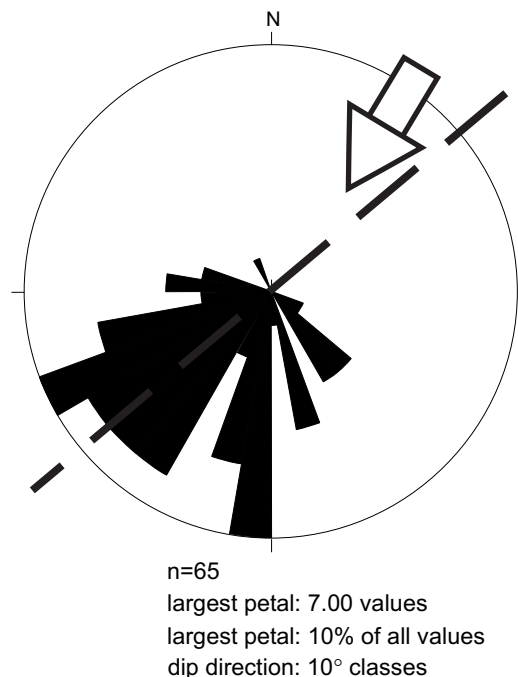

Fig. 10. Distribution of palaeocurrent direction in the esker succession in the pit, mean vector shown by arrow

Azimuth of mean vector V — 211°, amount of resultant vector (coefficient of concentration) L — 73%, number of measurements n — 65; dashed line represents morphological axis of the landform (azimuth about 50°)

the resultant palaeoflow vector was 211° (Fig. 10). The value of the resultant vector (coefficient of concentration) $L=73\%$ indicates that material transport by meltwaters occurred towards the south-west along the ice crevasse.

In the esker flank, within sand and gravel deposits, occur flasers and lenses flow tills and gravel pockets containing irregular till clasts, forming complexes watermorainic successions (*sensu* Morawski, 1984, 1989) characteristic of an ice-contact zone — in this case a contact with the ice crevasse walls. Such deposits, characteristic of esker flank zones and partly covering its glaciofluvial deposits, were described by Michalska (1971) as the “crevasse series”.

As at Kronowo, glaciofluvial sand and gravel deposits over 10 metres thick compose also narrow eskers which run longitudinally west of Jeziorany (see Fig. 1).

At the Kronowo exposure, the sand and gravel esker succession is underlain by a 1.5–3 m-thick till (Figs. 8 and 9). This is a highly compact dark grey till with a cherry hue at the top and bottom. The till occurs only within the ice crevasse composing a basal layer of its fill. This layer lies at the same depth, or slightly lower, as the base of till composing the glacial plateau surrounding the esker (Fig. 4).

The esker succession fills a tunnel cut in the Vistulian Glaciation till (Figs. 4 and 7), from several up to over 20 m thick (Morawski, 2003*a*).

The petrographic composition of the gravels and the composition of the heavy minerals (Kenig, 2000, unpubl.) indicate that the 3 tills (flow till covering the esker succession, the bed at its base, and the till of the glacial plateau) may be assigned to the Main Stadial of the Vistulian Glaciation.



Fig. 11. Southward-tilted glaciotectionic fold — southern fan fold limb in SW part of the pit (in 1998)

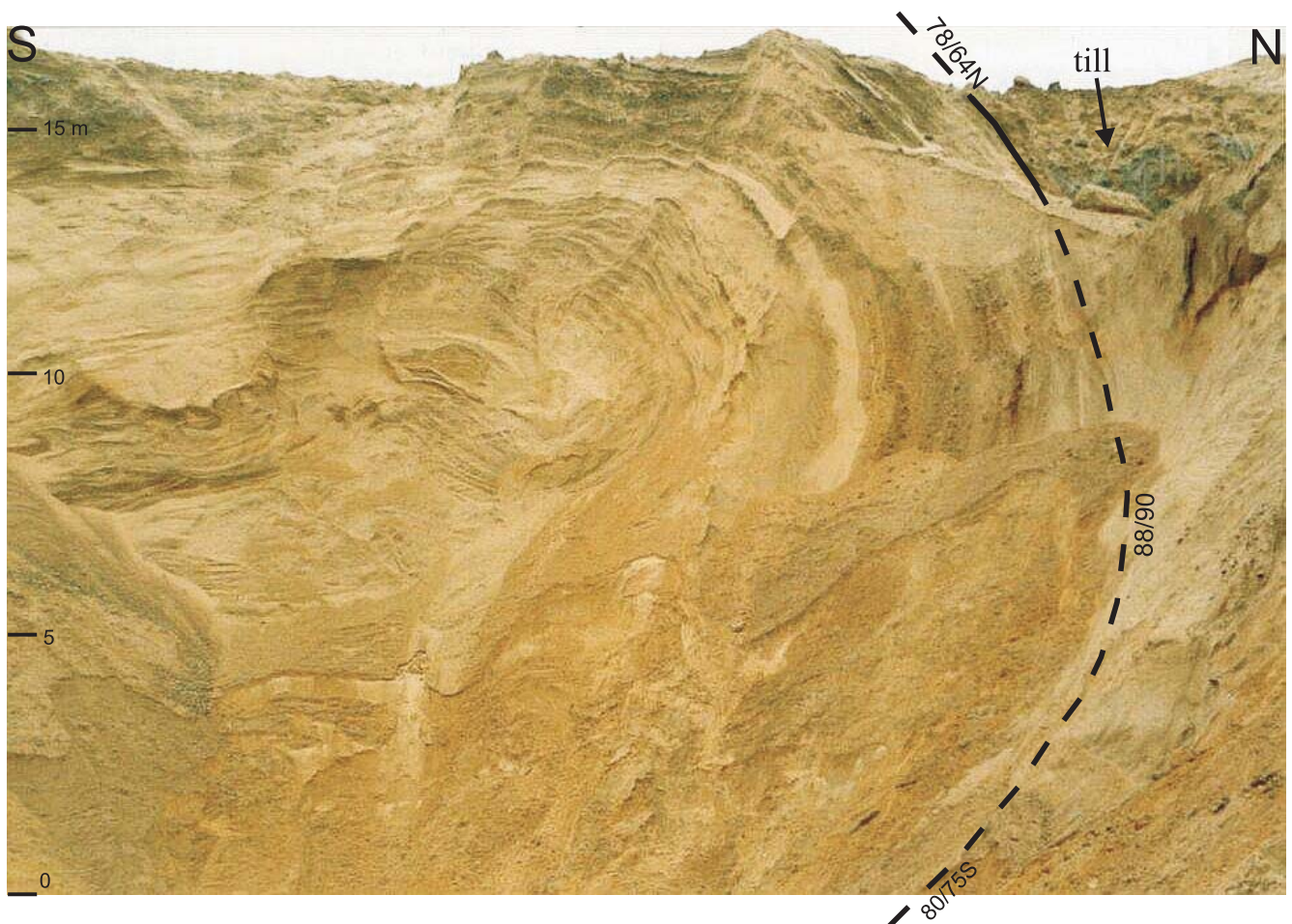

Fig. 12. Southward-tilted glaciotectionic fold — southern fan fold limb in NE part of the pit (in 2000) (left-hand side in Figure 8)



Fig. 13. Northward-tilted glaciotectonic fold — northern fan fold limb in NE part of the pit (in 2000) (right-hand side in Figure 8)

All of these data indicate that the Kronowo esker was formed in an open ice crevasse that reached the base of the ice, and partly even in a tunnel eroded in the sub-ice basement. However, it cannot be precluded that initially this could have been a subglacial tunnel.

GLACIOTECTONIC DEFORMATIONS

Detailed analysis of the topographic trend of the Kronowo esker indicates that this is not a continuous ridge, and its individual parts are shifted relative to each other and arranged en echelon (Fig. 7). Planes along which these shifts occurred represent NW–SE oriented strike-slip faults (see “wrench fault structures” — Rotnicki, 1972). One of these faults shifts the quarried gravel and sand deposit, causing the NE quarrying works to be relocated 80 m northwards. These are glaciotectonic faults caused by NW–SE oriented horizontal stress exerted by the active ice body (Fig. 6C). The faults may have followed original joints of the NW–SE set in the ice sheet (oblique to the original general direction of ice sheet movement) (Figs. 5b and 6A). The ice movement resulted in the faulting, and occurred both after the crevasse had been filled with sand and gravel deposits, and after glaciotectonic folding. The recent morphological axis of the esker shows an arcuate trend (Fig. 2). The azimuths of the esker axis in its SW and central part range from 30 to 40°, whereas in the north–east the axis runs at about 50°. Taking into account the ice sheet advance from the north, the en echelon pattern of the esker (Fig. 7), and the orientation of other similar landforms observed in this area, it can be suggested that this is a secondary, glaciotectonic arcuate bend (Fig. 6C). It is also possible that the NE part of the esker was rotated



Fig. 14. Glaciotectonic thrust in till of the basal layer in NE part of pit (central part in Figure 9)

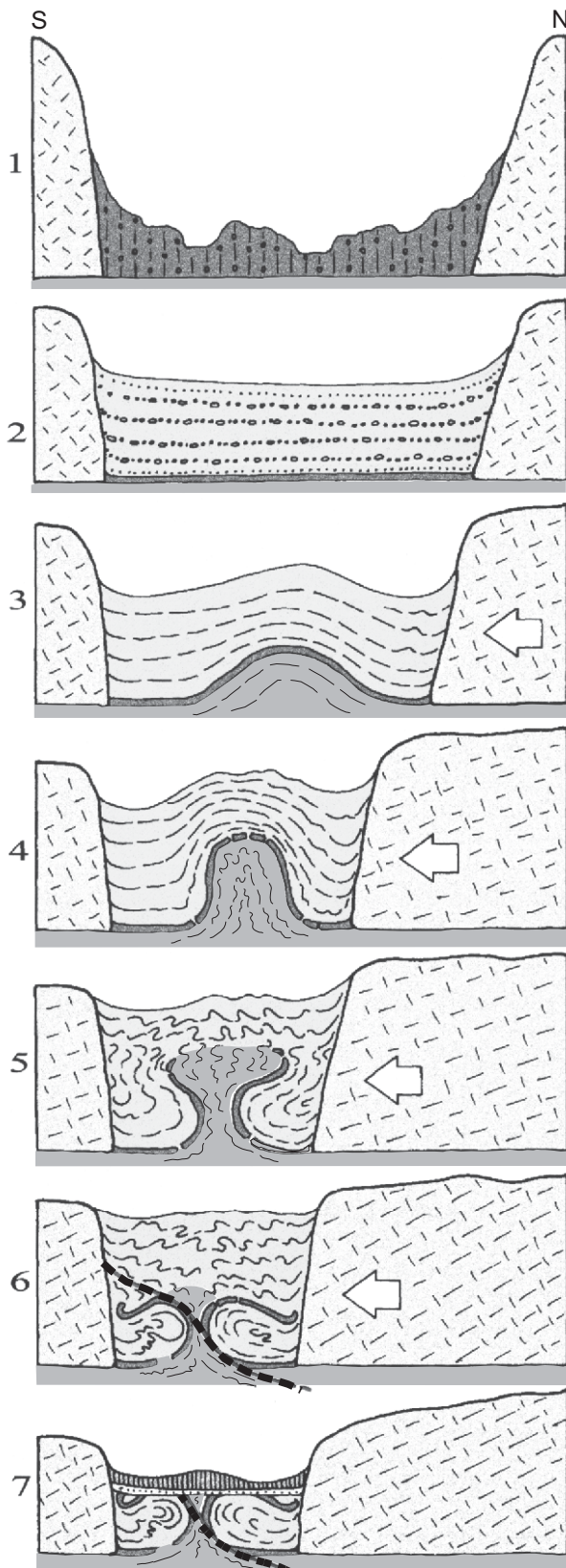

Fig. 15. Development stages of the Kronowo crevasse infilling and glaciotectonic folding

1 — filling with diamicton, crevasse width about 160 m, 2 — post-erosion esker sand and gravel deposition, 3 — reactivated ice sheet in the north (arrow indicates the direction of ice sheet movement) made a crevasse-fill fold, 4–6 — successive phases of ice sheet movement and crevasse-fill folding, crevasse width reduced to about 80 m, 7 — deposition of flow till after periodic erosion

by 10–20°, i.e. its original azimuth could be about 30–40°. This possible en bloc rotation of the entire part of the esker, examined in detail, should be taken into consideration in both sedimentological investigations (palaeoflow direction in the crevasse) and structural studies. In the latter case the situation is more complicated since it is not known whether the possible rotation occurred prior to the crevasse-fill folding (as discussed hereafter) or perhaps later. If the rotation occurred after the folding, the orientation of fold structures would be secondary, and would not fully reflect the original, folding stress pattern.

The Kronowo esker deposits along with the basal till are glaciotectonically deformed forming a fan fold (Fig. 8). As the quarrying continued in 1998–2002, the fold was successively examined along a distance of over 500 m (Figs. 7, 11 and 12). Figures 8 and 9 show parts of the exposures during 2000. The azimuth of the fold axis is approximately 80°. The fold axis is not parallel to the morphological axis of the esker and runs along its northern side (Fig. 7). Such a position of the fold axis indicates that only the northern part of the exploited sand and gravel of the crevasse-fill was deformed, and deposits located in the central and southern part are undisturbed. The situation changes in the north-east of the pit where the fold axis follows the morphological axis of the esker. The fold is cut half-way across the pit by a strike-slip fault (Fig. 7), and its SW part is shifted towards the SE by approximately 80 m. Further to the NE, probably at another fault, the fold axis turns to run along the azimuth of about 55°. Thus, the folding of the crevasse-fill deposits — occurred prior to strike-slip faulting.

The SW part of the pit reveals only the southern fold limb (Fig. 11), because the deposit was exploited only on that side of the vertically arranged till. As the quarrying continued eastwards (Fig. 12), it was also possible to study parts of the northern fold limb (Fig. 13).

Observations of the fold's shape in both its limbs was made more accurate owing to the till, 1.5 to 3 m thick, which occurs at the base of the crevasse filling. A depositional succession overlying the till — channel lag, gravels and sands, sands, silty sands with ripples *etc.* — was also clearly visible in these fold limbs, both in a normal position in the lower portion of exposures and in a reverse position in its upper part (see Fig. 8). This fold is asymmetric with vergence towards the south (Fig. 8). In the west of the pit, the fold is broad and its southern limb is strongly tilted towards the south (Fig. 11). To the north-east (Fig. 7, cross-section a) the fold gradually narrows and tills, observed at the base of the infill succession in both fold limbs, get closer to each other (Fig. 8). Yet further to the NE (Fig. 7, cross-section b) both fold limbs are in contact and thrust over each other (Figs. 9 and 14). The strike of the thrust surface is about 80°. The surface is inclined northwards at an angle of 60–70°, indicating that the horizontal stress was directed from the north. This direction is also indicated by the fold asymmetry, and by small, more or less horizontal faults observed in both fold limbs, in particular in the northern limb (Figs. 8 and 13). The till under the esker succession in the lower parts of both fold limbs, north and south of its axis, lies horizontally in its original position. Towards the axis, the layer is arcuately bent to reach a vertical position, and is inclined towards both sides. The arc diameter is about 20 m. The till in both the exposures and boreholes (Fig. 8 — S fold limb), was dislocated by

the bending and squeezed upwards. In the S fold limb, in cross-section a (Fig. 7), this break is about 10 m long (Fig. 8). In the N fold limb, the till was truncated by a thrust surface, as seen in the exposures east of the cross-section b (Fig. 9). The till and esker sequence were studied at upper portions of both fold limbs in a reverse position. This enabled full interpretation of the entire fan fold, shown by dashed lines in Figure 8.

The upper part of the fold, together with the deformed esker succession, is erosionally truncated and unconformably overlain by a flow till succession, as noted above.

All the data collected indicate that the original width of the crevasse in the Vistulian Glaciation ice sheet was approximately 200 m. This crevasse was subsequently initially filled with morainic sediments (diamicton) (Fig. 15, phase 1), probably originating from mud flows and/or from the melting collapsed tunnel roof. This sediment was probably subjected to short-lived erosion and subsequently deposited as till, up to several metres thick. This phase was followed by the deposition of a sand and gravel succession, over 20 m thick (Fig. 15, phase 2), transported from the NE.

After sedimentation and filling of the ice crevasse, probably already during the initial deglaciation, the ice sheet advanced southwards for a short time (Fig. 15, phases 3–6). Only part of the ice sheet, located on the north-west of the crevasse, was presumably active at that time. The southeastern area was covered by stagnant ice (dead ice) (Fig. 6C). This ice sheet advance resulted in deformation and upward squeezing of the crevasse-fill (Fig. 15, phases 4–6) (see Rotnicki, 1960*b*). Squeezing of both the crevasse-fill and underlying deposits was initiated and took place also with a contribution of vertical (loading) stress of the ice body, as was the case during formation of diapiric structures in ice-free areas (Brodzikowski, 1980), and in eskers (Wasilowska and Rotnicki, 1962), squeezed eskers or till-cored eskers (Rotnicki, 1960*a, b*). However, the vergence of glaciotectonic structures, and the shift of individual parts of the esker by strike-slip faults, indicate a strong lateral push of the ice from N to S. Such a push resulted in the formation of a large fan fold which was subsequently broken and tilted towards both sides, and partly truncated by a thrust (Fig. 15, phases 5 and 6). In the area exposed by quarrying, the distance over which the temporarily reactivated ice sheet advanced (magnitude of glaciotectonic narrowing of the ice crevasse) was determined as the sum of deformed and broken strata, and amounts to about 80 m.

Subsequent movement of the ice sheet also resulted in en bloc and en echelon shifting of the crevasse-fill. The general direction of the shift was towards the S and SE (Figs. 7 and 6C). Individual shifts within the esker ridge can be estimated at 20–80 m. It can be approximated that local advance of the ice sheet in the Kronowo region was about 150 m.

The upper portion of the folded crevasse-fill was probably eroded by meltwaters. These deposits were subsequently covered by diamicton flowing down into the crevasse from melting dead ice blocks (Fig. 15, phase 7).

These observations indicate that the Kronowo esker was formed by a crevasse-filling process in the continuously active ice sheet, or maybe during the initial phase of its stagnation. Meltwater erosion was followed by deposition, and the crevasse was infilled with glaciofluvial sediments. Both these phases took place probably during ice sheet stagnation, at the

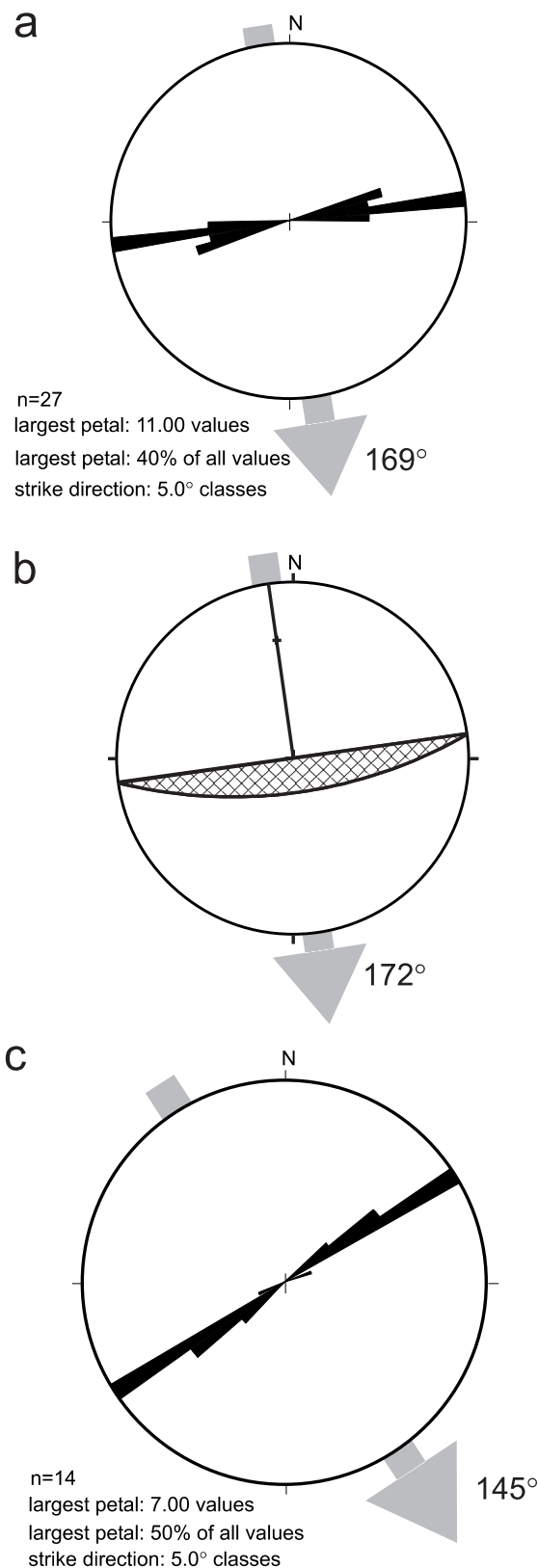

Fig. 16. Spatial orientation of glaciotectonic deformations in the pit exposure

a — stratal strikes in both fan fold limbs in the western and central parts of the pit, b — orientation of thrust surface on the Wulf net (projected onto northern hemisphere), c — stratal strikes in both fan fold limbs in east of the pit; arrows indicate the resultant vector of stress (direction of ice sheet movement), azimuth value shown near arrows

contact of active and dead ice. Deformation of the crevasse-fill, and en bloc shifts by strike-slip faults, should be therefore considered as the final act of the ice sheet activity.

ORIENTATION OF GLACIOTECTONIC DEFORMATIONS AND ICE-MOVEMENT DIRECTION

Glaciotectonic fan fold observed at Kronowo was formed probably as a result of periodic narrowing of the ice crevasse. The process of upward-squeezing of the crevasse-fill and partly also of the underlying glaciofluvial deposits (in a fold core) was probably caused by the same ice sheet movement which subsequently triggered strike-slip faulting across the esker ridge. Therefore, there was a local advance of the ice sheet from NNW towards SSE immediately prior to the retreat. Reconstruction of the axes of both fold limbs (Fig. 16a) and thrust surfaces (Fig. 16b) allowed determination of the resultant vector of folding stress, which reflects the local direction of ice sheet movement.

Average azimuths of fold axial traces, measured in exposures along a distance of about 500 m, are 77° for the southern fold limb, and 78° for the northern fold limb. The azimuth of the thrust surface strike is 82° . Thus, the direction of folding stress in the exposed area of the Kronowo pit can be defined by the azimuth of the stress vector, which varies from about 169° to 172° (Fig. 16a, b).

The NE portion of the fold is very narrow, and the N fold limb is thrust over the southern one. Here, the fold axis is oriented differently. The azimuth of the axial surface strike is approximately 55° (Fig. 16c), and is similar to the orientation of the crevasse (Fig. 7). This distinct change in orientation of the fold over a short distance between strike-slip faults seems to suggest a rotation of this block, associated with shifting along fault planes.

The Kronowo exposures provided a unique material for extremely precise determination of the direction of ice sheet movement during a short-lived period of its activity that occurred prior to the final deglaciation.

By comparing this direction of ice sheet movement with the direction observed during the ice sheet advance and determined from the analysis of orientation of glacial linear landforms (azimuth about 179°), I can infer that a small change in the direction of ice sheet movement by approximately 10° took place during the Main Stadial of the Vistulian Glaciation in the study area. These considerations are accurate if a possible rotation of NE portion of the Kronowo esker is precluded. However, if the rotation did take place, then it had occurred before the fold was formed, i.e. that rotation was unrelated to the strike-slip faulting. If such a rotation had really occurred, then folding stress would have been directed towards the NW, i.e. the change in the direction of ice sheet movement during the Main Stadial of the Vistulian Glaciation may have been considerably greater — about $20\text{--}30^\circ$ (Fig. 6A, C).

Disregarding the amount of change in the direction of ice sheet movement during the Main Stadial of the Vistulian Glaciation, it is essential that the data obtained refer to the general direction of ice sheet movement in an area located far from the ice sheet front.

DISCUSSION AND CONCLUSIONS

On the basis of the available data it can be suggested that the Kronowo region was covered by the Vistulian Glaciation ice sheet only during the Main Stadial. This area represents an extensive glacial plateau developed due to areal deglaciation, far from the marginal zone.

Morpholineaments. Analysis of the orientation of both positive and negative linear glacial landforms (morpholineaments) in this area shows that they developed along a original joint (crevasse) net in the ice body. All of the studies performed seem to indicate that this is a classical joint net composed of a rectangular system (extensional system, composed of a longitudinal set and a transverse set), and a system at angle to this (a shear system, composed of 2 diagonal sets), developed due to horizontal stress. This joint (crevasse) system could develop in the ice body due to the advancing ice sheet, i.e. its spatial orientation suggests the general direction of ice sheet movement.

It is uncertain whether the 4 morpholineament sets (crevasses in the ice) should be considered as a complementary system, i.e. the sets developed simultaneously as a result of the same processes, or whether these are 2 separate systems: a shear system composed of 2 oblique (diagonal) sets, and an extensional (rectangular) system composed of a longitudinal set and a transverse set. These two sets, superimposed on each other, would form a pattern similar both to a classical joint pattern in folded and unfolded areas and to the so-called “planetary joint” which, in addition, shows the same spatial orientation relative to geographical directions as the direction of glacial morpholineaments in the study area. Further investigations are needed to determine whether these 2 systems developed simultaneously.

In either case, ice fissures probably developed due to horizontal stress caused by ice sheet movement. Such a stress field resulted in both the shear (oblique system) and bending (rectangular system), pushing up being associated with the ice advance, and curving related to adjustment of the ice sheet to topographic irregularities.

It is necessary to establish the orientation of individual types of glacial landforms. Thus, for example, the route of glacial tunnel valleys and other linear landforms is most frequently non-perpendicular to the ice front, except for the set parallel to the direction of ice sheet advance. Simplifying, e.s. for mapping purposes in the field, 2 sets of glacial tunnel valleys or landforms (glacial morpholineaments) developed in ice crevasses and forming an acute angle (although nearly a right angle), the most probable direction of ice sheet movement during advance (joint-forming phase) can be defined by the resultant of this angle.

This hypothesis suggests verification of the theory of the formation of subglacial tunnel valleys and eskers. It is commonly considered that these landforms, in particular glacial tunnel valleys, are oriented according to the direction of ice sheet movement, and they are perpendicular to the ice sheet front. In case of ice sheet tongues in marginal zones, it results in the development of fan-like patterns. It should be born in mind that such patterns are typical of tongues of mountain glaciers. These develop by tension, as the tongues advance on to a broader area in front of a narrow U-shaped valley. A similar process can take place in elongated ice sheet tongues which

cover lowland areas, but the process cannot be considered general. Therefore, if the pattern of glacial tunnel valleys and landforms deposited in crevasses of lowland ice sheets is non-perpendicular to the ice sheet front, then it can indicate that, despite theoretical assumptions, subglacial waters were not squeezed from beneath the ice into its forefield through the shortest way (perpendicularly to the ice front) (Piotrowski, 1999), but these waters were directed along fissures in the ice body. This means that subglacial tunnel valleys, both N-type ones developed in the substrate (Nye, 1973), and R-type tunnels created at the ice sheet base (Röthlisberger, 1972), were formed according to a system of zones of englacial water outflows, associated with a fissure system in the ice. It also means that cryogenic pressure, tightening crevasses in the ice body, was balanced by the hydrostatic pressure of englacial waters widening the crevasses. Ice crevasses were probably not single surfaces but wider zones of crushed ice. Even if these zones were tightened due to the advancing ice sheet, they were certainly initial zones where migration of englacial waters was easier as compared with that in solid ice. Therefore, these zones were used by waters and gradually widened.

At this stage of studies it cannot be unambiguously stated whether the original pattern of ice (joints) fissures, inferred from the orientation of morpholineaments, really reflects the direction of ice sheet movement. Previous fragmentary and random observations seem to suggest that the observed glacial morpholineament systems are oriented like similar systems in other, even remote areas (e.g. Piątkowska, 2003).

Further detailed regional studies, including of glacial linear landforms of various ice sheets, should explain whether the system orientation is variable and strictly dependent on local directions of ice sheet movement, or whether it depends on a regional or even global stress field as, for example, in the case of the so-called "planetary joint" (common joint, original joint). It is also necessary to explain the mechanism of the formation and preservation of such a spatially oriented and ordered crevasse system within Pleistocene ice sheets in terms of the commonly accepted palaeo-ice stream pattern theory, in particular with regard to the last glaciation (see Marks, 2002).

Glaciotectionic deformations. The ability to define local directions of ice sheet movement from the spatial orientation of

compressional glaciotectionic deformations is less controversial. It seems that the tangential stress of the ice sheet on deposits subjected to deformation directly influenced the shape of deformations. The situation is more complicated if we take into considerations pre-existing fissure surfaces (joint net) in the ice sheet, along which local movements of the ice body could occur. The Kronowo esker was transected by strike-slip faults oriented obliquely to the accurately determined folding stress. The ice sheet push, exerted on deposits filling a crevasse that trends obliquely to the direction of this push, probably caused the crack to curve. Individual ice sheet blocks advanced not in the same direction as the main ice mass, but moved along crack surfaces, as was the case with strike-slip faults.

Prior to deglaciation, temporary reactivation of the stagnant ice sheet took place in the Kronowo region. It resulted in glaciotectionic compressional deformation of the crevasse-fill (esker deposits). Analysis of the orientation of these deformations allowed determination of the folding direction of ice sheet movement from NNW towards SSE. The comparison of this direction with the assessed direction of ice sheet movement during the ice advance allowed determination of changes in the direction of ice sheet movement at this site during the entire Main Stadial of the Vistulian Glaciation. The change in the azimuth of the ice sheet movement vector is 10° (or as much as $20\text{--}30^\circ$, if rotation occurred). Initially, the ice sheet advanced from the north, and during the final phase from NNW towards SSE.

Despite some uncertainties, it is striking that the directions of ice sheet movement, obtained as a result of numerous, accurate measurements taken during both geomorphological and glaciotectionic analysis, are very similar.

These results should be treated as simplified and preliminary. They are based on regular patterns obtained during detailed field studies. Further investigations should take into account that local changes in directions of ice sheet movement, caused by various factors, can explain such regularities on a regional scale. The concept of relating morpholineaments to a system of original crevasses in the ice body, as well as conclusions on the direction of ice sheet movement inferred from the net orientation, also requires fundamental theoretical study of the mechanics of ice sheets.

REFERENCES

- AARIO R. (1977) — Classification and terminology of morainic landforms in Finland. *Boreas*, **6** (2): 87–100.
- ABER J. S., CROOT D. G. and FENTON M. M. (1989) — Glaciotectionic landforms and structures. Kluwer Acad. Publ.
- ABER J. S. and RUSZCZYŃSKA-SZENAICH H. (1997) — Origin of Elbląg Upland, northern Poland, and glaciotectionism in the southern Baltic region. *Sedimentary Geol.*, **111**: 119–134.
- BARTKOWSKI T. (1968) — On the essence of glaciotectionics (in Polish with English summary). *Prz. Geol.*, **16** (10): 455–461.
- BER A. (1987) — Glaciotectionic deformation of glacial landforms and deposits in the Suwalki Lakeland (NE Poland). In: *Tills and Glaciotectionics* (ed. J. J. M. van der Meer): 135–143. A. A. Balkema, Rotterdam.
- BER A. (2000) — Pleistocene of north-eastern Poland and neighbouring areas against crystalline and sedimentary basement (in Polish with English summary). *Pr. Państw. Inst. Geol.*, **170**.
- BERGDAHL A. (1953) — Marginal deposits in south-eastern Sweden. With special reference to the oses. *Lund studies in Geography, ser. A Phys. Geogr.*, **4**.
- BOULTON G. S. (1975) — Processes and patterns of subglacial sedimentation: a theoretical approach. In: *Ice Ages: Ancient and Modern* (eds. A. E. Wright and F. Moseley). *Geol. J. Spec. Iss.*, **6**: 7–42.
- BOULTON G. S. (1996) — Theory of glacial erosion, transport and deposition as a consequence of subglacial sediment deformation. *J. Glaciol.*, **42**: 43–62.

- BRODZIKOWSKI K. (1980) — Glacitectonic — problems in genetic classification of disturbances (in Polish with English summary). III Sympozjum glacitektoniki, Zielona Góra, 33–47.
- BRODZIKOWSKI K. (1982) — Deformation of unconsolidated sediments in areas glaciated during the Pleistocene with southwest Poland as an example (in Polish with English summary). *Acta Univ. Wratisl.*, **57**, 4.
- BRODZIKOWSKI K. (1987) — The environmental basis of glacitectonism in central Europe (in Polish with English summary). *Acta Univ. Wratisl.*, **93**, 4.
- CROOT D. G. ed. (1988) — Glaciotectonics forms and processes. A. A. Balkema, Rotterdam.
- DADLEZ R. and JAROSZEWSKI W. (1994) — Tektonika. PWN.
- DOKTÓR S., GRANICZNY M. and KUCHARSKI R. (1995) — Sprawozdanie z opracowania mapy liniowych elementów strukturalnych Polski w skalach 1:200 000 i 1:500 000 na podstawie kompleksowej analizy komputerowej zdjęć geofizycznych i teledetekcyjnych. Państw. Inst. Geol.
- GLEN J. W., DONNER J. J. and WEST R. G. (1957) — On the mechanism by which stones in till become oriented. *Am. J. Sc.*, **255**.
- GRANICZNY M. (1989) — Fotolineamenty i ich znaczenie geologiczne. *Instr. Met. Bad. Geol.*, **50**.
- GRIPP K. (1938) — Endmoränen. *Comptes Rendus du Congrès Inter. De Geogr. Ila. Amsterdam*.
- GRUSZKA B. and MORAWSKI W. (2003) — Sedymentacja w szczelinie aktywnego i stagnującego lodu. Stanowisko Kronowo. In: *Kemy i ozy — stary problem w nowym, sedymentologicznym ujęciu*. Teren. Warsz. Sedyment.
- HART J. K. (1995) — Subglacial erosion, deposition and deformation associated with deformable beds. *Prog. Phys. Geogr.*, **19** (2): 173–191.
- KARCZEWSKI A. (1963) — Morphology structure and texture of the ground moraine area of west Poland. *Poznańskie Tow. Przyj. Nauk, Wd. Mat.-Prz.*, Pr. Kom. Geogr.-Geol., **4** (2).
- KASPRZAK L. (1985) — The origin of glacitectonic deformations within the push-moraine near Leszno. *Bad. Fizjogr. nad Pol. Zach.*, ser. A, **35**: 63–82.
- MAJDANOWSKI S. (1947) — Distribution, density and direction of lakechannels of the Polish Lowlands (in Polish with English summary). *Prz. Geogr.*, **21** (1–2): 37–63.
- MAJDANOWSKI S. (1950) — The problem of lake channels in the European Plain. *Bad. Fizjogr. nad Pol. Zach.*, **2** (1): 35–122.
- MAŃKOWSKA A. and SŁOWAŃSKI W. (1968) — Mapa Geologiczna Polski 1:200 000, arkusz Olsztyn. Inst. Geol.
- MAŃKOWSKA A. and SŁOWAŃSKI W. (1980) — Objaśnienia do Mapy Geologicznej Polski 1:200000, arkusz Olsztyn. Inst. Geol.
- MARKS L. (1988) — Relation of substrate to the Quaternary palaeorelief and sediments, western Mazury and Warmia (northern Poland). *Zesz. Nauk. A.G.H.*, 1165. *Geol. Kwart.*, **14** (1).
- MARKS L. (1992) — Osady i formy rzeźby terenu. In: *Czwartorzęd* (ed. L. Lindner): 53–273. PAE.
- MARKS L. (2002) — Last glacial maximum in Poland. *Quater. Sc. Rev.*, **21**: 103–110.
- MICHALSKA Z. (1971) — Origin of eskers, as exemplified by eskers of Middle Poland (in Polish with English summary). *Stud. Geol. Pol.*, **36**.
- MORAWSKI W. (1984) — Watermorainic sediments (in Polish with English summary). *Pr. Instyt. Geol.*, **108**.
- MORAWSKI W. (1985) — Pleistocene glacial sediments of the watermorainic facies. *Quater. Stud.*, **6**: 99–116.
- MORAWSKI W. (1989) — Watermorainic sediments: origin and classification. In: *Genetic Classification of Glacigenic Deposits: 143–144*. A. A. Balkema, Rotterdam.
- MORAWSKI W. (1999) — Maximum limit of the Vistulian Glaciation in the vicinity of Nidzica, southwestern Mazury Lakeland. *Geol. Quart.*, **43** (1): 61–67.
- MORAWSKI W. (2000) — Liniowe formy polodowcowe, a liniowe elementy strukturalne w rejonie Olsztyna (południowo-zachodnie Mazury). In: *Dorobek i pozycja polskiej geomorfologii u progu XXI wieku. V Zjazd Geomorfologów Polskich*. Toruń.
- MORAWSKI W. (2003a) — Szczegółowa Mapa Geologiczna Polski w skali 1:50 000 arkusz Jeziorany. Państw. Inst. Geol.
- MORAWSKI W. (2003b) — Prowincje sedymentacyjne plejstocenu w NE Polsce. In: *Plejstocen Kotliny Raciborsko-Oświęcimskiej na tle struktur podłoża czwartorzędu*. X Konferencja: Sratygrafia plejstocenu Polski. Sosnowiec.
- MORAWSKI W. (in print a) — Struktury glacitektoniczne w rejonie Nidzicy (zachodnie Mazury). *Pr. Państw. Instyt. Geol.*
- MORAWSKI W. (in print b) — Stratygrafia i paleogeografia czwartorzędu rejonu Nidzica-Orłowo. *Pr. Państw. Instyt. Geol.*
- MORAWSKI W. and KENIG K. (1999) — Lithology of the Late Pleistocene sands for stratigraphic and palaeographic correlation in Muszaki area, southwestern Mazury Lakeland. *Geol. Quart.*, **43** (1): 69–78.
- MOTYL-RAKOWSKA J. and SCHOENEICH K. (1970) — Geology of the southwestern slope of the Masurian anticline. *Acta Geol. Pol.*, **20** (4): 771–794.
- NYE J. F. (1973) — Water at the bed of a glacier. *Symposium on the Hydrogeology of Glaciers*. IAHS Publ., **95**: 189–194.
- PASIERBSKI M. (1984) — The structure of end moraines as one of the indicators of the mode of deglaciation of the last glaciation area in Poland (in Polish with English summary). *Rozprawy UMK*.
- PIĄTKOWSKA A. (2003) — Cechsztyńsko-mezozoiczny kompleks strukturalny Kujaw w świetle cyfrowej analizy danych teledetekcyjnych. *Instr. Met. Bad. Geol.*, Państw. Instyt. Geol., **57**.
- PIOTROWSKI J. A. (1987) — Genesis of the Woodstock drumlin field, southern Ontario, Canada. *Boreas*, **16**: 249–265.
- PIOTROWSKI J. (1999) — Channelized subglacial drainage under soft-bedded ice sheets: evidence from small N-channels in Central European Lowland. *Geol. Quater.*, **43** (2), 153–162.
- PIWOCKI M. (in print) — Trzeciorzęd rejonu Nidzicy. *Pr. Państw. Instyt. Geol.*
- ROTNICKI K. (1960a) — Survey of problems concerning eskers. *Czas. Geogr.*, **31** (2): 191–218.
- ROTNICKI K. (1960b) — Oz bukowsko-mosinski. *Pozn. Tow. Przyj. Nauk, Pr. Kom. Geogr.-Geol.*, **2** (2)
- ROTNICKI K. (1972) — Glaciotectonic wrench-falut structure from Jastrzębniki near Kalisz (in Polish with English summary). *Pr. Komis. Geogr.-Geol. Pozn. Tow. Przyj. Nauk*, **13** (1): 191–210.
- ROTNICKI K. (1974) — Ogólne podstawy teoretyczne powstawania deformacji glacitektonicznych. I Sympozjum glacitektoniki: 41–59.
- ROTNICKI K. (1976) — The theoretical basis for and a model of the origin of glacitectonic deformations. *Questiones Geogr.*, **3**: 103–139.
- ROTNICKI K. (1988) — Methodological basis of dating glacitectonic deformations (in Polish with English summary). *Bad. Fizjogr. nad Pol. Zach. ser. A*, **38**: 51–81.
- RÖTHLISBERGER H. (1972) — Water pressure in intra- and subglacial channels. *J. Glaciol.*, **11**: 177–203.
- RUSZCZYŃSKA-SZENAJCH H. (1983) — Słownik tektoniczny cz. XIV. Glacitektonika. *Prz. Geol.*, **31** (8–9): 502–505.
- RUSZCZYŃSKA-SZENAJCH H. (1998) — Struktury glin lodowcowych jako istotny wskaźnik ich genezy. In: *Struktury sedymentacyjne i postsedymentacyjne w osadach czwartorzędowych i ich wartość interpretacyjna* (ed. E. Mycielska-Dowgiałło): 13–40. *Wyd. Geogr. Stud. Region. UW*.
- RUSZCZYŃSKA-SZENAJCH H. (1999) — Direction of the last ice advance in the Polish Baltic coast recorded by glacitectonic structures and landforms. *Quater. Stud. Pol., Spec. Issue*: 195–202.
- SHAW J. (1977) — Till body morphology and structure related to glacier flow. *Boreas*, **6** (2): 189–201.
- STANKOWSKI W. (1975) — Orientation of pebbles expressing the movement of the ice-sheet found in the district of Konin. *Bad. Fizjogr. nad Pol. Zach.*, **28** A: 181–190.
- Van den MEER J. J. M. ed (1987) — Tills and glacitectonics. A. A. Balkema, Rotterdam.
- WASIŁOWSKA K. and ROTNICKI K. (1962) — Oz lubaski. *Bad. Fizjogr. nad Pol. Zach.*, **9**: 95–125.
- WYSOTA W. (1994) — Morphology, internal composition and origin of drumlins in the southeastern part of the Chełmno-Dobrzyń Lakeland, North Poland. *Sediment. Geol.*, **91** (1–4): 345–364.
- ZIELIŃSKI T. (1992) — Marginal moraines of NE Poland — sediments and depositional conditions (in Polish with English summary). *Pr. Nauk. UŚL*, **1325**.